

The following page(s) are extracted from multi-page Kuhnke product catalogues or CDRoms and any page number shown is relevant to the original document. The PDF sheets here may have been combined to provide technical information about the specific product(s) you have selected.

Hard copy product catalogues, and CDRoms have been published describing Kuhnke Pneumatics, Solenoids, Relays and Electronics; some divided into different books. A list of current publications is available on this web site or from our sales offices. Some may be available for download, but as substantially larger files.

Contact Details

Kuhnke sales and service in North America

Kuhnke
Automation Inc.
P.O Box 1369
Wayne, N.J.

T: (973) 633 0690
F: (973) 633 7230
Email: sales@kuhnkeusa.com

Important Note

The information shown in these documents is for guidance only. No liability is accepted for any errors or omissions. The designer or user is solely responsible for the safe and proper application of the parts, assemblies or equipment described.

Regulators

Series 50 Manifold Regulator

Kuhnke System Logic Devices

Manifold Mounted Miniature Pressure Regulator

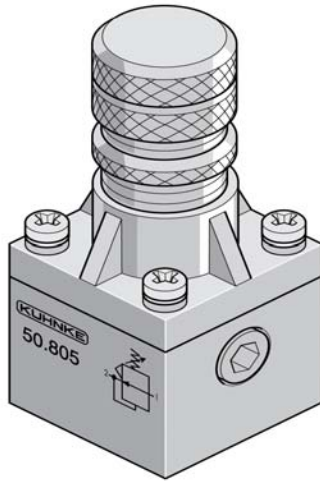

The manifold mounted regulator provides regulation of air pressures from 0 to 145 PSI. The miniature regulator is available in both relieving and non-relieving versions in a nickel-plated brass housing. The unit is provided with a third port for connection of a pressure gauge.

A large brass knob provides for adjustment throughout the regulator's range. A setting lock nut is included to prevent tampering after adjustment. Two adjustment ranges are available as standard, for close regulation in most applications. Special designs are available.



Technical Specifications

Op. Pressure:

0-145 PSI

Regulator Range:

0-115 PSI

Porting:

Manifold mounted.

Flow Rate:

Dependent on regulator model.
See charts.

Media:

Filtered air.

Types:

Relieving or non-relieving.
Single stage, diaphragm/
spring construction.

Response Time:

(Dependent on secondary volume).
Response average: 45ms at 20%
loss of secondary air pressure;
100ms at 50% loss of secondary
air pressure.

Adjustment:

Knob Adj. Equipped with locking nut
to prevent tampering after setting is
made.

Materials:

Brass housing nickel-plated,
stainless and brass interior parts,
Buna N seals.

Operating Ambient:

0° C to +60° C (32° F to 140° F)

Dimensions:

Height – 2 5/16"
Width – 1 3/16" Square
Weight – 9 1/2 ozs.

Drilling Plan:

See drawing.

Selection Chart

Secondary Pressure Regulation Range	Catalog Number	
	Relieving Type	Non- Relieving Type
0 - 115 PSI (8 Bar)	50805-00-80-00	50805-00-80-10
0 - 15 PSI (1 Bar)	50805-00-10-00	50805-00-10-10

Diagrams

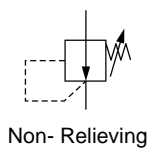
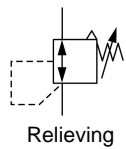

Operation

Relieving type regulators allow excessive pressure on the secondary side of the regulator to bleed off to the atmosphere, helping maintain steady pressure. Non-relieving types are used where pressure build up is not a concern as in air motors, or air gun applications etc.

Flow Chart

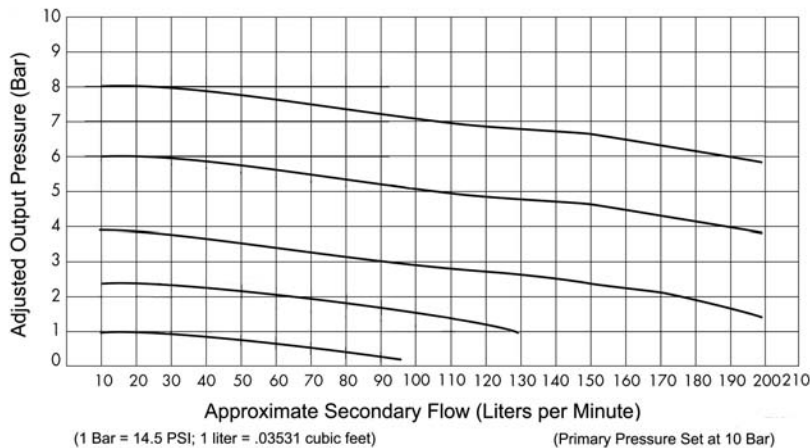

Drilling Plan

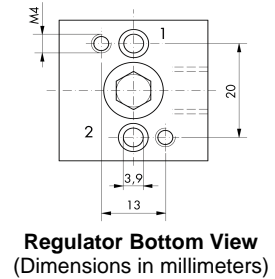

Manifold Section for Regulators

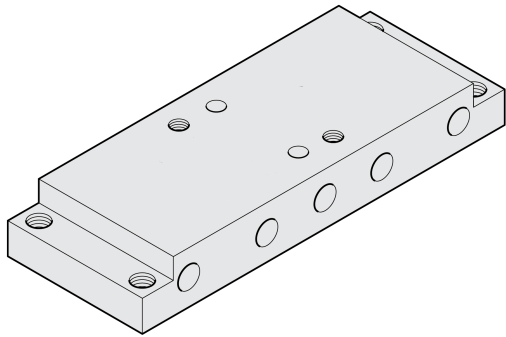

50800

Aluminum base is used for mounting manifold type regulators on Kuhnke Series 84 manifold systems to regulate supply pressure to downstream valves. Base connects air supply to regulator input. Output sends lowered air pressure to the manifold valves on the secondary side. With the addition of a header kit (Cat. no. 84465), the section can be used as a mounting base for regulators. See Series 84 valves for details on the manifold system.