



The following page(s) are extracted from multi-page Kuhnke product catalogues or CDROMs and any page number shown is relevant to the original document. The PDF sheets here may have been combined to provide technical information about the specific product(s) you have selected.

Hard copy product catalogues, and CDROMs have been published describing Kuhnke Pneumatics, Solenoids, Relays and Electronics; some divided into different books. A list of current publications is available on this web site or from our sales offices. Some may be available for download, but as substantially larger files.

Contact Details

Kuhnke sales and service in North America

Ellis/Kuhnke Controls
132 Lewis Street
Unit A-2, Eatontown
NJ 07724
USA

T: (800) 221 0714
T: (732) 291 3334
F: (732) 291 8154

Important Note

The information shown in these documents is for guidance only. No liability is accepted for any errors or omissions. The designer or user is solely responsible for the safe and proper application of the parts, assemblies or equipment described.

Regulators

Series 50 Miniature Regulator

Kuhnke System Logic Devices

Sub - Miniature Pressure Regulator



Regulator with optional Knob

The sub-miniature Series 50 regulator provides regulation of air pressure from 0 to 115 PSI. Available in both relieving and non-relieving versions, the unit's size and shape makes it ideally suited for mounting in dental, medical and laboratory equipment where close regulation and fine adjustments are necessary.

The regulator is supplied with a panel nut for mounting in a 1/2 inch diameter hole. It can be screw driver adjusted, and set with a locking nut, or with the use of a control knob can be continuously adjusted. Ports (2) have 10-32 (M5) threads and are 180° apart on the side of the regulator body. The housing is nickel plated brass.

Several adjustment ranges are available for close regulation in most applications. Special designs are available.



Technical Specifications

Op. Pressure:

0-145 PSI

Regulator Range:

0-115 PSI

Porting:

10-32 (M5).

Flow Rate:

Dependent on regulator model. See charts.

Media:

All neutral liquid and gaseous media. Consult factory before use on liquids.

Types:

Relieving or non-relieving. Single stage, diaphragm/spring construction.

Response Time:

(Dependent on secondary volume).
Response average: 75ms at 20% loss of secondary air pressure;
1 sec at 50% loss of secondary air pressure.

Adjustment:

Screw driver (or knob accessory).
Equipped with locking nut to prevent tampering after setting is made

Materials:

Brass housing (nickel plated),
stainless and brass interior parts,
Buna N seals.

Operating Ambient:

-10°C to +60°C (-14°F to 140°F)

Dimensions:

Height – 1 11/16"
Width – 5/8" Hex Body
Weight - 2 ozs.

Drilling Plan:

Mounts in 1/2" dia. hole.
Equipped with mounting nut.
Behind panel depth – 1 1/8".

Selection Chart

Secondary Pressure Regulation Range	Catalog Number	
	Relieving Type	Non- Relieving Type
0 - 115 PSI (8 Bar)	50880-00-80-00	50880-00-80-10
0 - 60 PSI (4 Bar)	50880-00-40-00	50880-00-40-10
0 - 30 PSI (2 Bar)	50880-00-20-00	50880-00-20-10

Diagrams

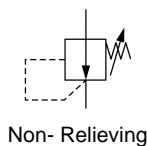
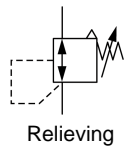

Accessories

The standard regulator is supplied with a slotted shaft for screwdriver adjustment. A plastic knob catalog number **50883-00** can be added for easy adjustment.

A flat mounting flange catalog number **43010-1** or an 'L' bracket catalog number **43010-2** can be used to mount the regulator on a surface. Brackets have (2) 1/8" dia. fastening holes and approximate dimensions are 1-9/16" wide x 1 1/16" high.

Operation

Relieving type regulators allow excessive pressure on the secondary side of the regulator to bleed off to the atmosphere, helping maintain steady pressure. Non-relieving types are used where pressure build up is not a concern as in air motors, or air gun applications etc.

Flow Chart

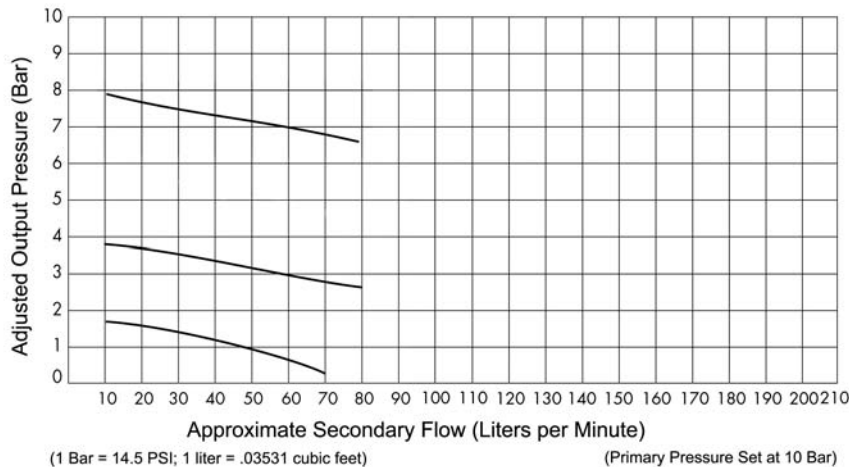

Manifold Section for Regulators

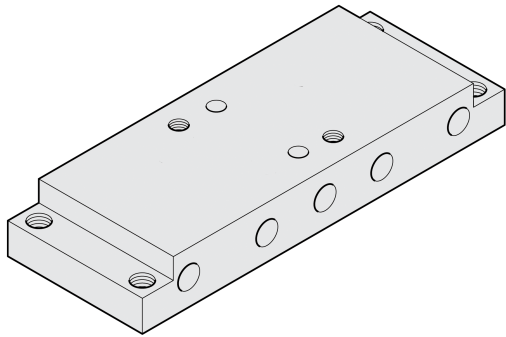

50800

Aluminum base is used for mounting manifold type regulators on Kuhnke Series 84 manifold systems to regulate supply pressure to downstream valves. Base connects air supply to regulator input. Output sends lowered air pressure to the manifold valves on the secondary side. With the addition of a header kit (Cat. no. 84465), the section can be used as a mounting base for regulators. See Series 84 valves for details on the manifold system.