



The following page(s) are extracted from multi-page Kuhnke product catalogues or CDROMs and any page number shown is relevant to the original document. The PDF sheets here may have been combined to provide technical information about the specific product(s) you have selected.

Hard copy product catalogues, and CDROMs have been published describing Kuhnke Pneumatics, Solenoids, Relays and Electronics; some divided into different books. A list of current publications is available on this web site or from our sales offices. Some may be available for download, but as substantially larger files.

## Contact Details

Kuhnke sales and service in North America

Ellis/Kuhnke Controls  
132 Lewis Street  
Unit A-2, Eatontown  
NJ 07724  
USA

T: (800) 221 0714  
T: (732) 291 3334  
F: (732) 291 8154

### Important Note

The information shown in these documents is for guidance only. No liability is accepted for any errors or omissions. The designer or user is solely responsible for the safe and proper application of the parts, assemblies or equipment described.

---

# Regulators

## Series 50 Miniature Regulator

Kuhnke System Logic Devices

### Miniature Pressure Regulator

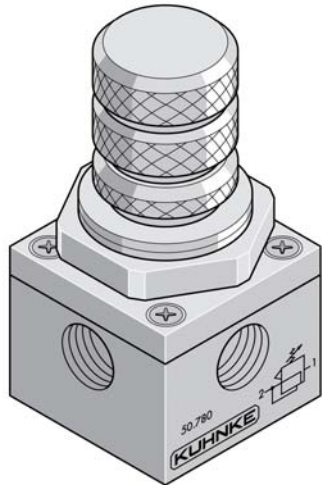

The miniature Series 50 regulator provides regulation of air pressures from 0 to 115 PSI. The regulator is available in both relieving and non-relieving versions. Housing is nickel-plated brass.

The regulator is supplied with a panel nut for mounting in a 1 inch diameter hole. A large brass knob provides for adjustment throughout the regulator's range. A setting lock nut is included to prevent tampering after adjustment. The regulator has a third port for connection of a pressure gauge. Primary and secondary ports are 180° apart on the side of the regulator body.

Several adjustment ranges are available for close regulation in most applications. Special designs are available.



### Technical Specifications

**Op. Pressure:**

0-145 PSI

**Regulator Range:**

0-115 PSI

**Porting:**

1/8 G or NPT

**Flow Rate:**

Dependent on regulator model.  
See charts.

**Media:**

Filtered air.

**Types:**

Relieving or non-relieving.  
Single stage, diaphragm/  
spring construction.

**Response Time:**

(Dependent on secondary volume).  
Response average: 45ms at 20%  
loss of secondary air pressure;  
100ms at 50% loss of secondary  
air pressure.

**Adjustment:**

Knob Adj. Equipped with locking nut  
to prevent tampering after setting is  
made.

**Materials:**

Brass housing nickel-plated,  
stainless and brass interior parts,  
Buna N seals.

**Operating Ambient:**

0° C to +60° C (32° F to 140° F)

**Dimensions:**

Height – 2 5/16"  
Width – 1 3/16" Square  
Weight – 9 1/2 ozs.

**Drilling Plan:**

Mounts in 1" dia. hole.  
Equipped with mounting nut.  
Behind panel depth - 11/s".

### Selection Chart

Secondary Pressure Regulation Range	Catalog Number	
	Relieving Type	Non- Relieving Type
<b>With 1/8 NPT ports...</b>		
0 – 90 PSI (6 Bar)	<b>50780-00US</b>	---
<b>With Metric G 1/8 ports...</b>		
0 - 115 PSI (8 Bar)	<b>50780-00-80-00</b>	<b>50780-00-80-10</b>
0 - 35 PSI (2.5 Bar)	<b>50780-00-25-00</b>	<b>50780-00-25-10</b>
0 - 15 PSI (1 Bar)	<b>50780-00-10-00</b>	<b>50780-00-10-10</b>

### Diagrams

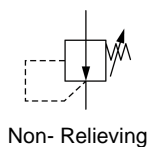
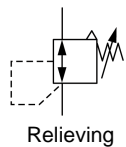

### Accessories

An 'L' shaped bracket catalog number **48255-100** can be used to mount the regulator on a flat surface using (2) 10-32 threaded holes on the rear of the unit.

### Operation

Relieving type regulators allow excessive pressure on the secondary side of the regulator to bleed off to the atmosphere, helping maintain steady pressure. Non-relieving types are used where pressure build up is not a concern as in air motors, or air gun applications etc.

### Flow Chart

