

The following page(s) are extracted from multi-page Kuhnke product catalogues or CDRoms and any page number shown is relevant to the original document. The PDF sheets here may have been combined to provide technical information about the specific product(s) you have selected.

Hard copy product catalogues, and CDRoms have been published describing Kuhnke Pneumatics, Solenoids, Relays and Electronics; some divided into different books. A list of current publications is available on this web site or from our sales offices. Some may be available for download, but as substantially larger files.

Contact Details

Kuhnke sales and service in North America

Kuhnke
Automation Inc.
P.O Box 1369
Wayne, N.J.

T: (973) 633 0690
F: (973) 633 7230
Email: sales@kuhnkeusa.com

Important Note

The information shown in these documents is for guidance only. No liability is accepted for any errors or omissions. The designer or user is solely responsible for the safe and proper application of the parts, assemblies or equipment described.

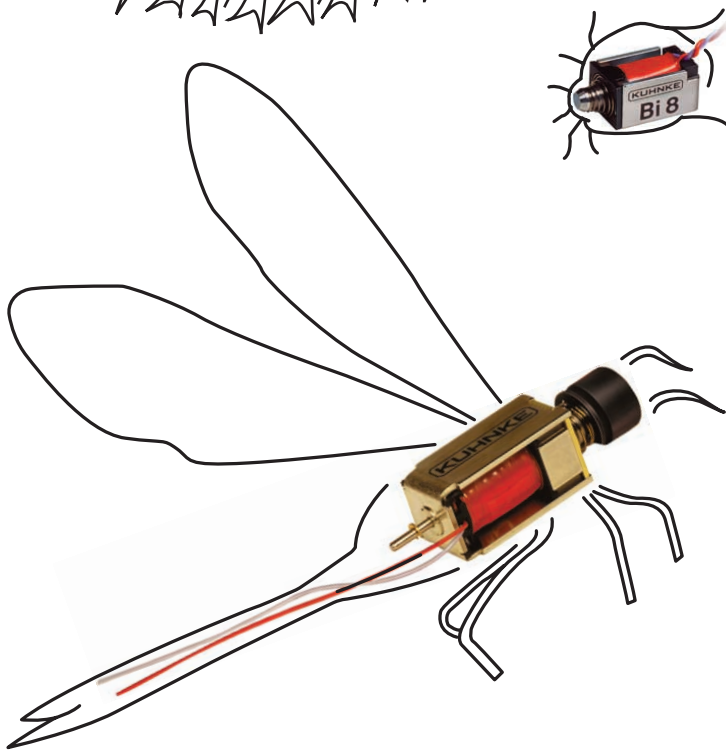
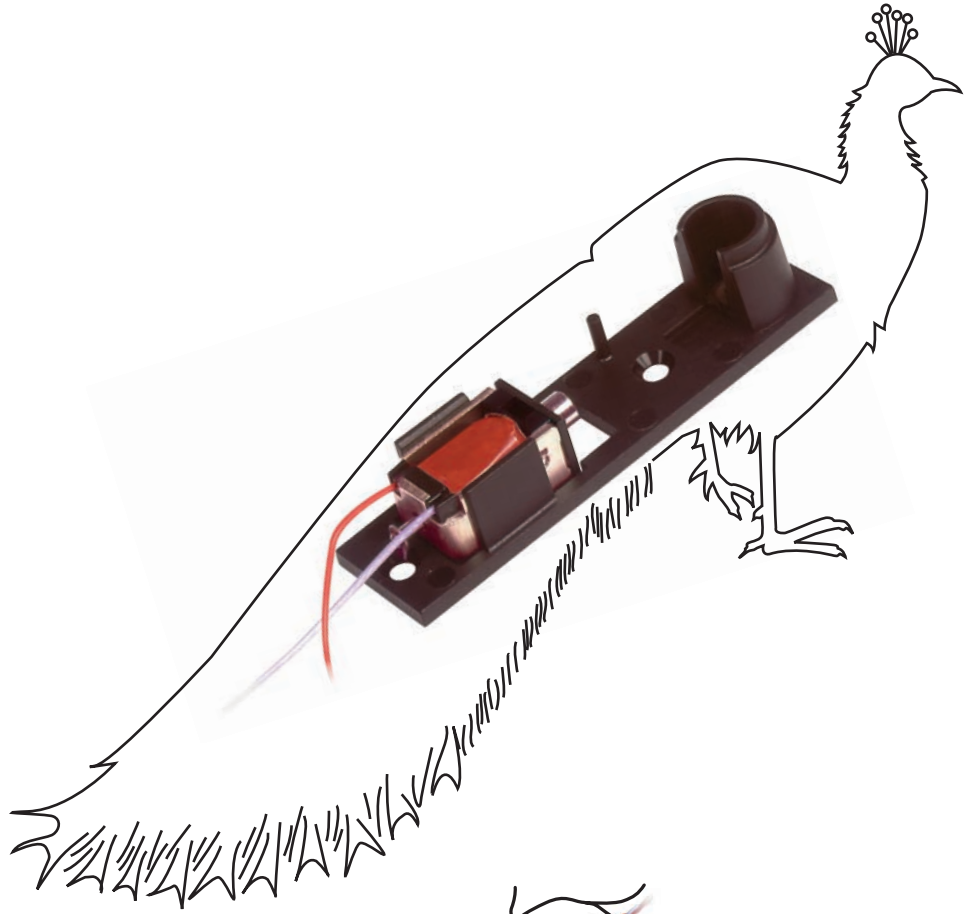

Bistable Solenoids

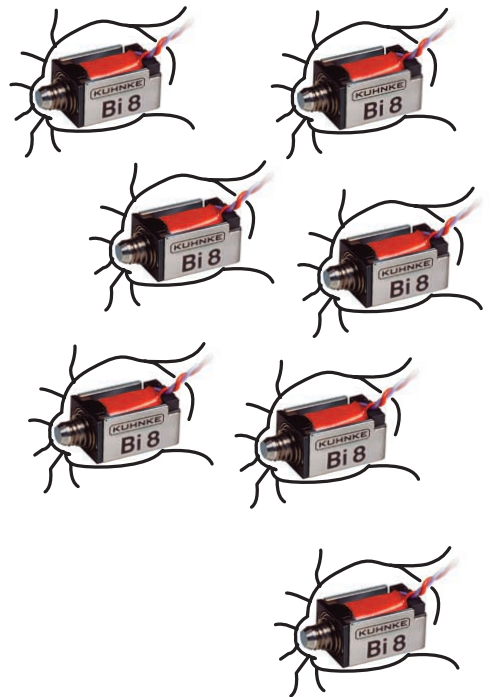

Bistabiler Hubmagnet BI 8

Bistable Linear Solenoid BI 8

Stoßende und ziehende Ausführung

Thrust and pull type

Bestellformel	BI	8	- F -	24 V DC	20 % ED	Order specifications
Hubmagnet	BI					Linear solenoid
Bauart		8				Design type
Anschlußart						Coil terminals
Litze (Standardlänge 10 cm)			F			Flying leads (10 cm standard length)
Lötpins (Rastermaß)			L			Soldering pins (grid dimensions)
Nennspannung (Standardspannung) ¹⁾				24		Nominal voltage (standard voltage) ¹⁾
Zulässige relative Einschaltdauer bei Luftkühlung (LK)					20 % ED	Perm. duty cycle under air cooled conditions (LK)

¹⁾ Die Magnete sind auf Anfrage bis 30 V DC lieferbar

¹⁾ Other voltages are available on request up to 30 V DC

Gewicht:
Magnet: ca. 6 g

Anker: ca. 1,6 g
Standard:
Spannung: 24 V DC
Litze: 10 cm
Isolierstoffklasse: E (T_{grenz} = 120 °C)

Isolationsgruppe nach: VDE 0110 C 75
Prüfspannung: 500 V (eff)
Schutzart: IP 00

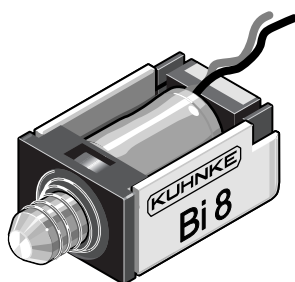

Weight:
Complete solenoid: appr. 6 g
Armature: appr. 1.6 g
Standard:
Voltage: 24 V DC
Flying leads: 10 cm
Insulation class: E (max. permissible temperature = 120 °C)

Insulation group according to: VDE 0110 C 75
Test voltage: 500 V (eff)
Protection: IP 00

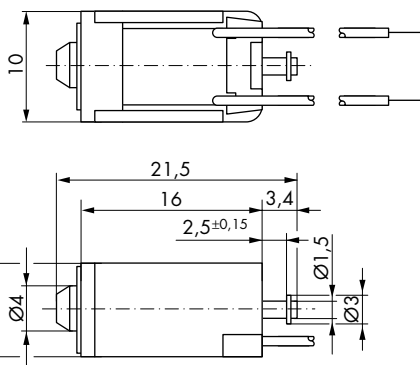

Maße im angezogenem Zustand

→
Hubrichtung

Dimensions given with armature in fully home position

→
Direction of stroke

Zul. rel. Einschaltdauer (ED)	%	20	%	Perm. duty cycle (ED)
Nennaufnahme P 20	W	5,6	W	Nominal coil power P 20
Anzugszeit (ED)	ms	12	ms	Actuation time (ED)
Abfallzeit	ms	7	ms	Drop-out time

Kraft-Weg-Diagramm F = f (s)

— — — Federkraft
- . - . - . Permanentkraft

Kraft bei waagerechter Bewegungsrichtung und bei 90 % Nennspannung und betriebswarmer Wicklung ohne Rückholfeder

Hub s = 0 entspricht dem angezogenen, bestromten Zustand

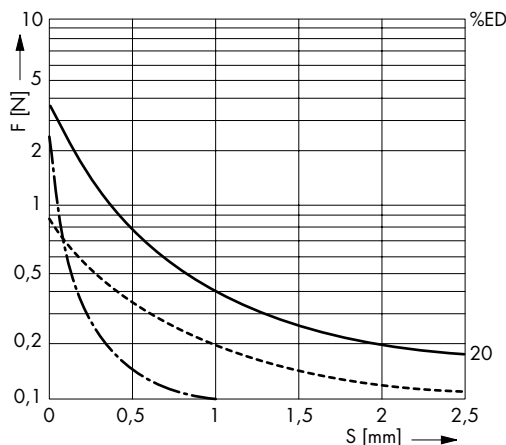

Force vs. Stroke diagramm F = f (s)

— — — spring force
- . - . - . permanent force

Force measured when operating in horizontal position, at 90 % rated voltage and with winding at operating temperature without return spring

stroke s = 0 corresponds to armature in fully home position

Stoßende und ziehende Ausführung

Thrust and pull type

Bestellformel	BI	13	- F -	24 V DC	25 % ED	Order specifications
Hubmagnet	BI					Linear solenoid
Bauart		13				Design type
Anschlußart						Coil terminals
Litze (Standardlänge 10 cm)			F			Flying leads (10 cm standard length)
Lötpins 0,63 (Rastermaß 8,9 mm)			L			Soldering pins 0.63 (grid dimensions 8.9 mm)
Nennspannung (Standardspannung) ¹⁾				24		Nominal voltage (standard voltage) ¹⁾
Zulässige relative Einschaltdauer bei Luftkühlung (LK)					25 % ED	Perm. duty cycle under air cooled conditions (LK)

¹⁾ Die Magnete sind auf Anfrage bis 30 V DC lieferbar

¹⁾ Other voltages are available on request up to 30 V DC

Gewicht:
Magnet: ca. 23 g

Anker: ca. 6 g
Standard:
Spannung: 24 V DC
Litze: 10 cm
Isolierstoffklasse: E ($T_{\text{grenz}} = 120\text{ °C}$)

Isolationsgruppe nach: VDE 0110 C 75
Prüfspannung: 500 V (eff)
Schutzart: IP 00

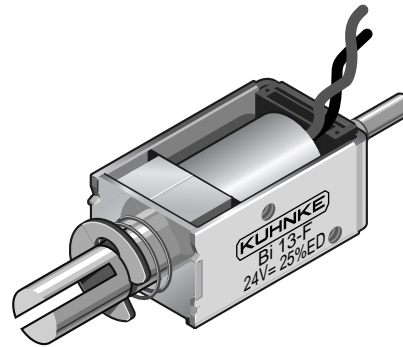

Weight:
Complete solenoid: appr. 23 g
Armature: appr. 6 g
Standard:
Voltage: 24 V DC
Flying leads: 10 cm
Insulation class: E (max. permissible temperature = 120 °C)

Insulation group according to: VDE 0110 C 75
Test voltage: 500 V (eff)
Protection: IP 00

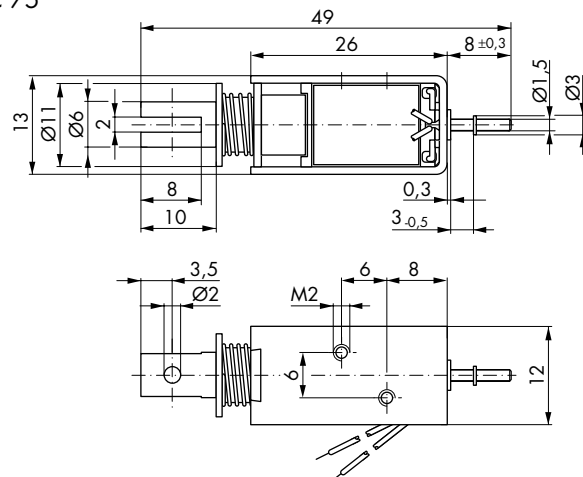

Maße im angezogenem Zustand

→
Hubrichtung

Dimensions given with armature in fully home position

→
Direction of stroke

Zul. rel. Einschaltdauer (ED)	%	25	%	Perm. duty cycle (ED)
Nennaufnahme P 20	W	7	W	Nominal coil power P 20
Anzugszeit (ED)	ms	14	ms	Actuation time (ED)
Abfallzeit	ms	12	ms	Drop-out time

Kraft-Weg-Diagramm $F = f(s)$

— — — Federkraft
- . - . - Permanentkraft

Kraft bei waagerechter Bewegungsrichtung und bei 90 % Nennspannung und betriebswarmer Wicklung ohne Rückholfeder

Hub $s = 0$ entspricht dem angezogenen, bestromten Zustand

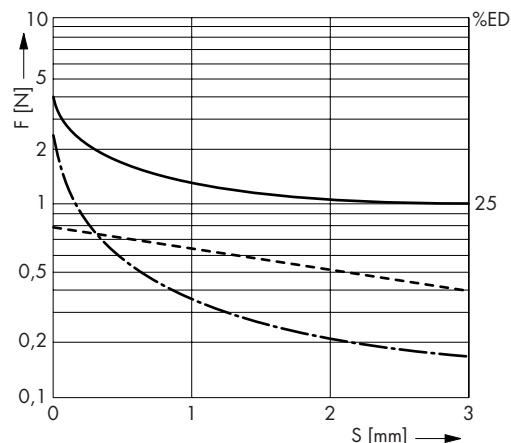

Force vs. Stroke diagramm $F = f(s)$

— — — spring force
- . - . - permanent force

Force measured when operating in horizontal position, at 90 % rated voltage and with winding at operating temperature without return spring

stroke $s = 0$ corresponds to armature in fully home position

Stoßende und ziehende Ausführung

Thrust and pull type

Bestellformel	BI	17	- F -	24 V DC	25 % ED	Order specifications
Hubmagnet	BI					Linear solenoid
Bauart		17				Design type
Anschlußart						Coil terminals
Litze (Standardlänge 10 cm)			F			Flying leads (10 cm standard length)
Nennspannung (Standardspannung) ¹⁾				24		Nominal voltage (standard voltage) ¹⁾
Zulässige relative Einschaltdauer bei Luftkühlung (LK)					25 % ED	Perm. duty cycle under air cooled conditions (LK)

¹⁾ Die Magnete sind auf Anfrage bis 60 V DC lieferbar

¹⁾ Other voltages are available on request up to 60 V DC

Gewicht:
Magnet: ca. 46 g
Anker: ca. 12 g
Standard:
Spannung: 24 V DC
Litze: 10 cm
Isolierstoffklasse: E (T_{grenz} = 120 °C)
Isolationsgruppe nach: VDE 0110 C 75
Prüfspannung: 800 V (eff)
Schutzart: IP 00

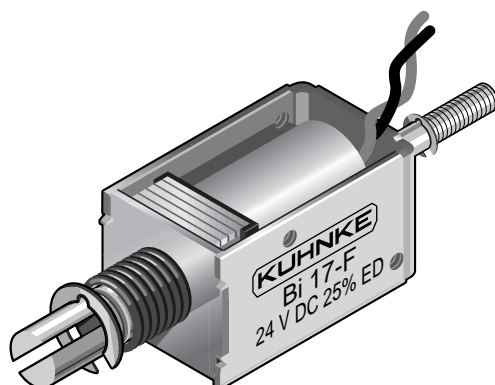

Weight:
Complete solenoid: appr. 46 g
Armature: appr. 12 g
Standard:
Voltage: 24 V DC
Flying leads: 10 cm
Insulation class: E (max. permissible temperature = 120 °C)
Insulation group according to: VDE 0110 C 75
Test voltage: 800 V (eff)
Protection: IP 00

Zul. rel. Einschaltdauer (ED)	%	25	%	Perm. duty cycle (ED)
Nennaufnahme P 20	W	9,5	W	Nominal coil power P 20
Anzugszeit (ED)	ms	22	ms	Actuation time (ED)
Abfallzeit	ms	11	ms	Drop-out time

Kraft-Weg-Diagramm F = f (s)

— — — Federkraft
- . - . - Permanentkraft

Kraft bei waagerechter Bewegungsrichtung und bei 90 % Nennspannung und betriebswarmer Wicklung ohne Rückholfeder

Hub s = 0 entspricht dem angezogenen, bestromten Zustand

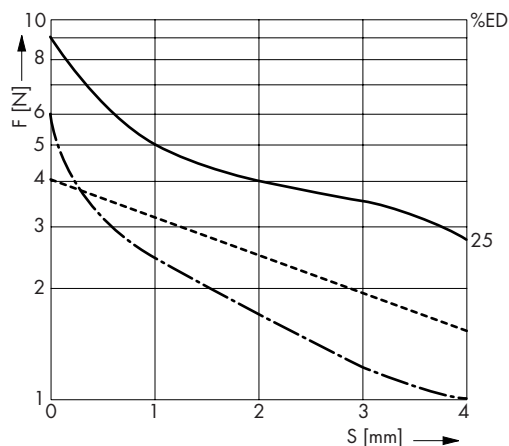

Force vs. Stroke diagramm F = f (s)

— — — spring force
- . - . - permanent force

Force measured when operating in horizontal position, at 90 % rated voltage and with winding at operating temperature without return spring

stroke s = 0 corresponds to armature in fully home position

Bistabiler Hubmagnet
BI 17

Bistable Linear Solenoid
BI 17

Stoßende und ziehende Ausführung

Thrust and pull type

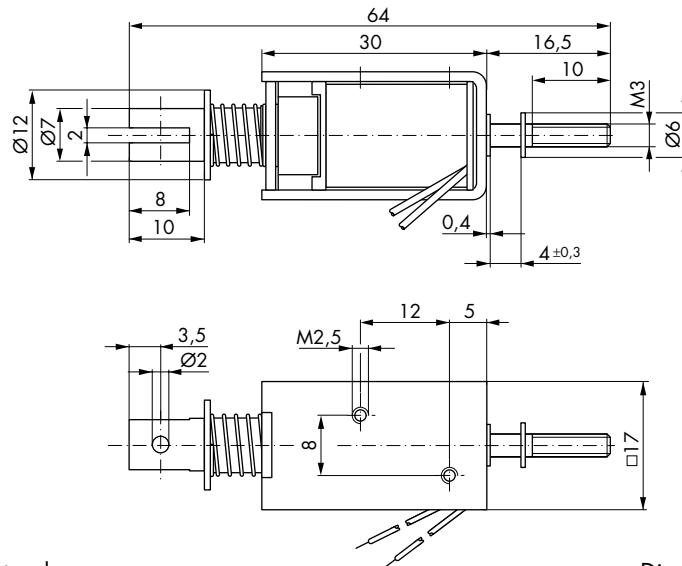

Maße im angezogenem Zustand

→
Hubrichtung

Dimensions given with armature
in fully home position

→
Direction of stroke

