

The following page(s) are extracted from multi-page Kuhnke product catalogues or CDRoms and any page number shown is relevant to the original document. The PDF sheets here may have been combined to provide technical information about the specific product(s) you have selected.

Hard copy product catalogues, and CDRoms have been published describing Kuhnke Pneumatics, Solenoids, Relays and Electronics; some divided into different books. A list of current publications is available on this web site or from our sales offices. Some may be available for download, but as substantially larger files.

Contact Details

Kuhnke sales and service in North America

Kuhnke
Automation Inc.
P.O Box 1369
Wayne, N.J.

T: (973) 633 0690
F: (973) 633 7230
Email: sales@kuhnkeusa.com

Important Note

The information shown in these documents is for guidance only. No liability is accepted for any errors or omissions. The designer or user is solely responsible for the safe and proper application of the parts, assemblies or equipment described.

Continuous Cycling Timer Circuit

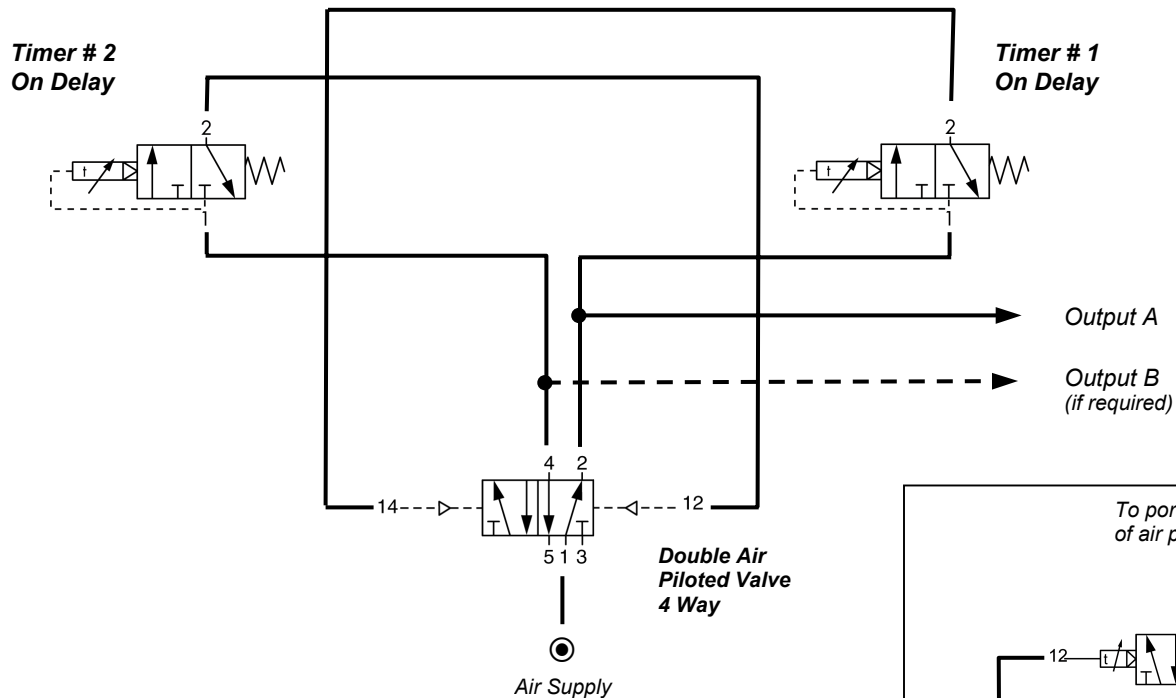

Continuous cycling is accomplished by the use of 2 timers operating a double air piloted valve. Off and on times are dependent on the type and set time of timers used. The size of the air piloted valve determines the air volume output. The position of the air piloted valve determines the start up of the timing sequence. If the timing sequence must be restarted in a specific order, a reset circuit must be added at port 12 of the air piloted valve to move it to the start position prior to resuming operation.

Operation

System pressure is turned on. Air flows through port 2 of the pilot valve to drive timer #1 and the device being controlled. When timer 1 reaches set time, it sends a signal to port 14 of the pilot valve, switching the air output to port 4, starting the timing sequence on timer #2 and shutting down timer 1 and the output to the device being controlled. When timer 2 reaches set time, a signal is sent to port 12 of the piloted valve resetting it and restarting the cycle.

Typical Item Selection

Timers- Any on delay timer. (Consider length of time required and mounting preference.)
 Double Air Piloted Valve- Cat. nos. 81014 (10-32 ports), 75027-71-42 (1/8), 75047-81-42 (1/4), or 75067-81-42 (1/2).

